

JE Sharda
AD
SD
PA
D.P.

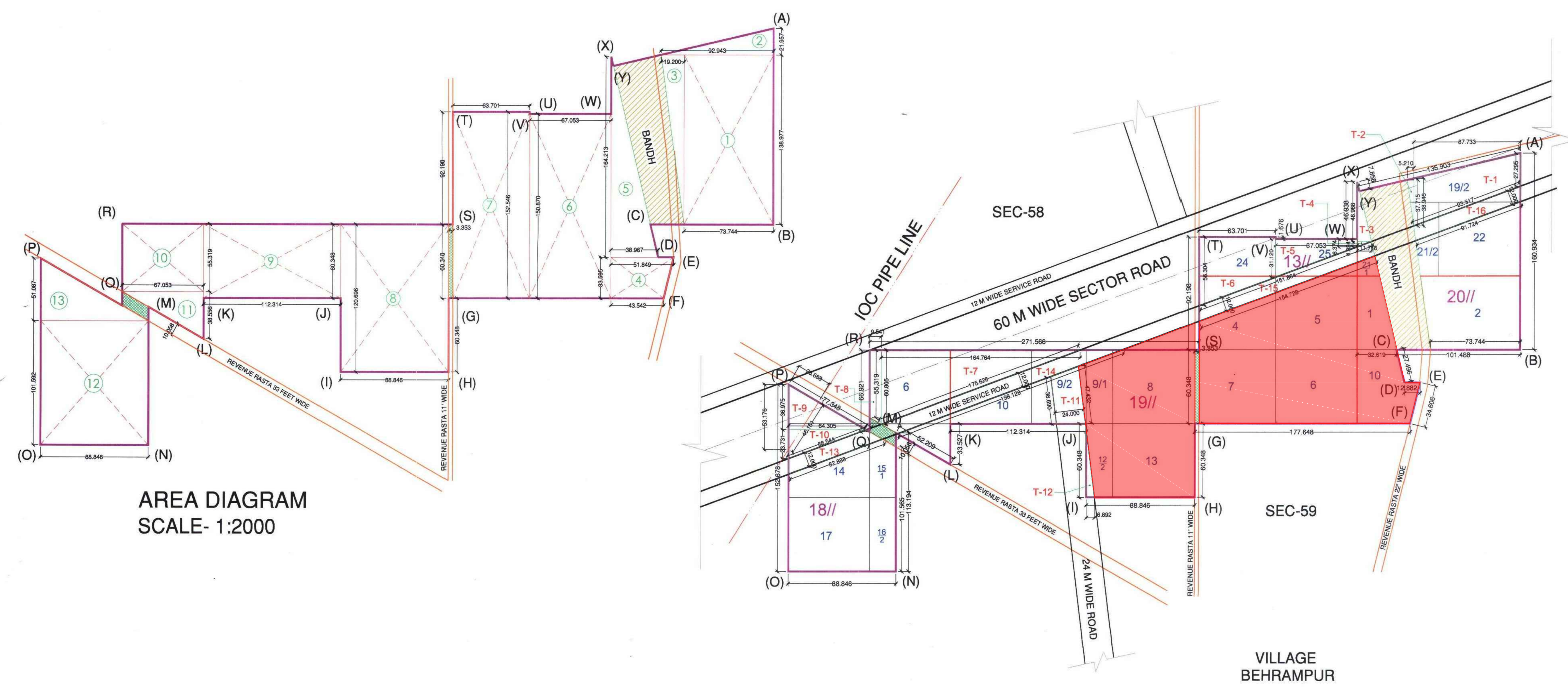

AREA DIAGRAM
SCALE- 1:2000

AREA DETAIL OF PLOT

PLOT ENCLOSED BY POINTS
A,B,C,D,E,F,G,H,I,J,K,L,M,N,O,P,Q,R,S,T,U,V,W,X AND Y

(1)	= 73.744 x 138.977	=	10248.719 SQ.M
(2)	= 0.5 x 92.943 x 21.957	=	1020.374 SQ.M
(3)	= 0.5 x 19.200 x 138.977	=	1334.179 SQ.M
(4)	= 0.5 (43.542+51.849) x 33.595	=	1602.330 SQ.M
(5)	= 0.5 x 38.967 x 164.213	=	3199.443 SQ.M
(6)	= 67.053 x 150.87	=	10116.286 SQ.M
(7)	= 63.701 x 152.546	=	9717.332 SQ.M
(8)	= 88.846 x 120.696	=	10723.356 SQ.M
(9)	= 112.314 x 60.348	=	6777.925 SQ.M
(10)	= 67.053 x 55.319	=	3709.304 SQ.M
(11)	= 0.5 x 67.053 x 38.556	=	1292.647 SQ.M
(12)	= 88.846 x 101.592	=	9026.042 SQ.M
(13)	= 0.5 x 88.846 x 51.087	=	2269.437 SQ.M

TOTAL AREA = 71037.374 SQ.M
OR = 17.55 ACRES

AREA UNDER ROADS

1. AREA UNDER 60 M WIDE SECTOR ROAD

T1	= 0.5(38.946+27.295) x 87.733	=	2905.761 SQ.M
T2	= 0.5 x 5.21 x 37.715	=	98.247 SQ.M
T3	= 0.5 x 11.718 x 48.988	=	287.021 SQ.M
T4	= 0.5 x 4.324 x 11.718	=	25.334 SQ.M
T5	= 0.5 (31.12+6.374)+67.053	=	1257.042 SQ.M
T6	= 0.5 (56.304+32.796) x 63.701	=	2837.879 SQ.M
T7	= 0.5 x 60.805 x 164.764	=	5009.237 SQ.M
T8	= 0.5(55.319+60.805) x 9.541	=	553.969 SQ.M
T9	= 0.5 x 64.305 x 36.975	=	1188.838 SQ.M
T10	= 0.5 x 64.305 x 23.731	=	763.011 SQ.M
TOTAL		=	14926.339 SQ.M

2. AREA UNDER 24 M WIDE SECTOR ROAD

T11	= 0.5(38.69+47.432) x 24	=	1033.464 SQ.M
T12	= 0.5 x 6.892 x 60.348	=	207.959 SQ.M
TOTAL		=	1241.423 SQ.M (0.307 ACS)

3. AREA UNDER 12 M WIDE SERVICE ROAD

T13	= 0.5(82.888+68.544) x 12	=	908.592 SQ.M
T14	= 0.5(198128+175.626) x 12	=	2242.524 SQ.M
T15	= 0.5(154.728+151.864) x 12	=	1839.552 SQ.M
T16	= 0.5(91.724+93.517) x 12	=	1111.446 SQ.M
TOTAL		=	6102.114 SQ.M (1.508 ACS)

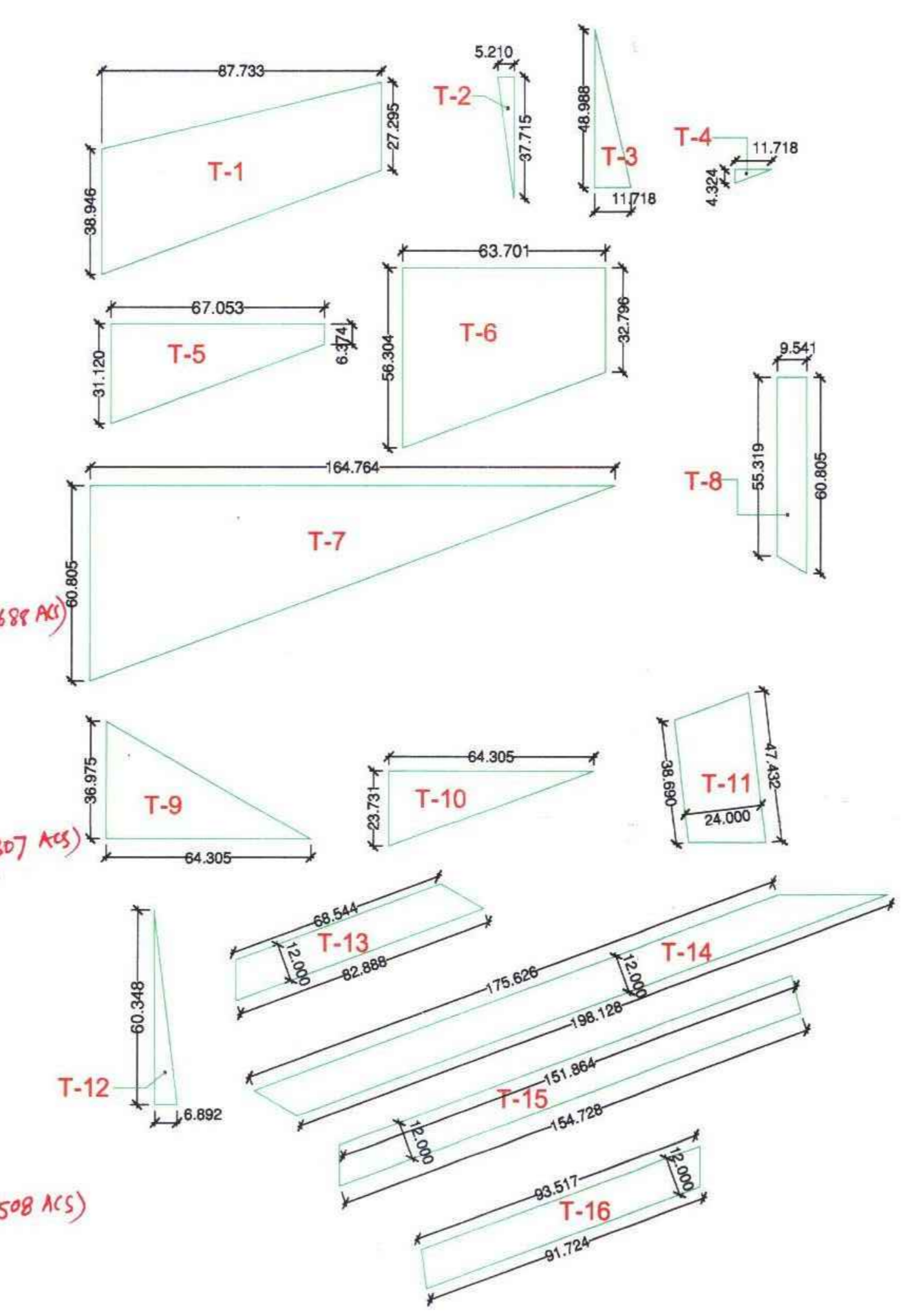

SITE PLAN SHOWING KHASARA DETAILS AND PROPOSED SECTOR ROADS

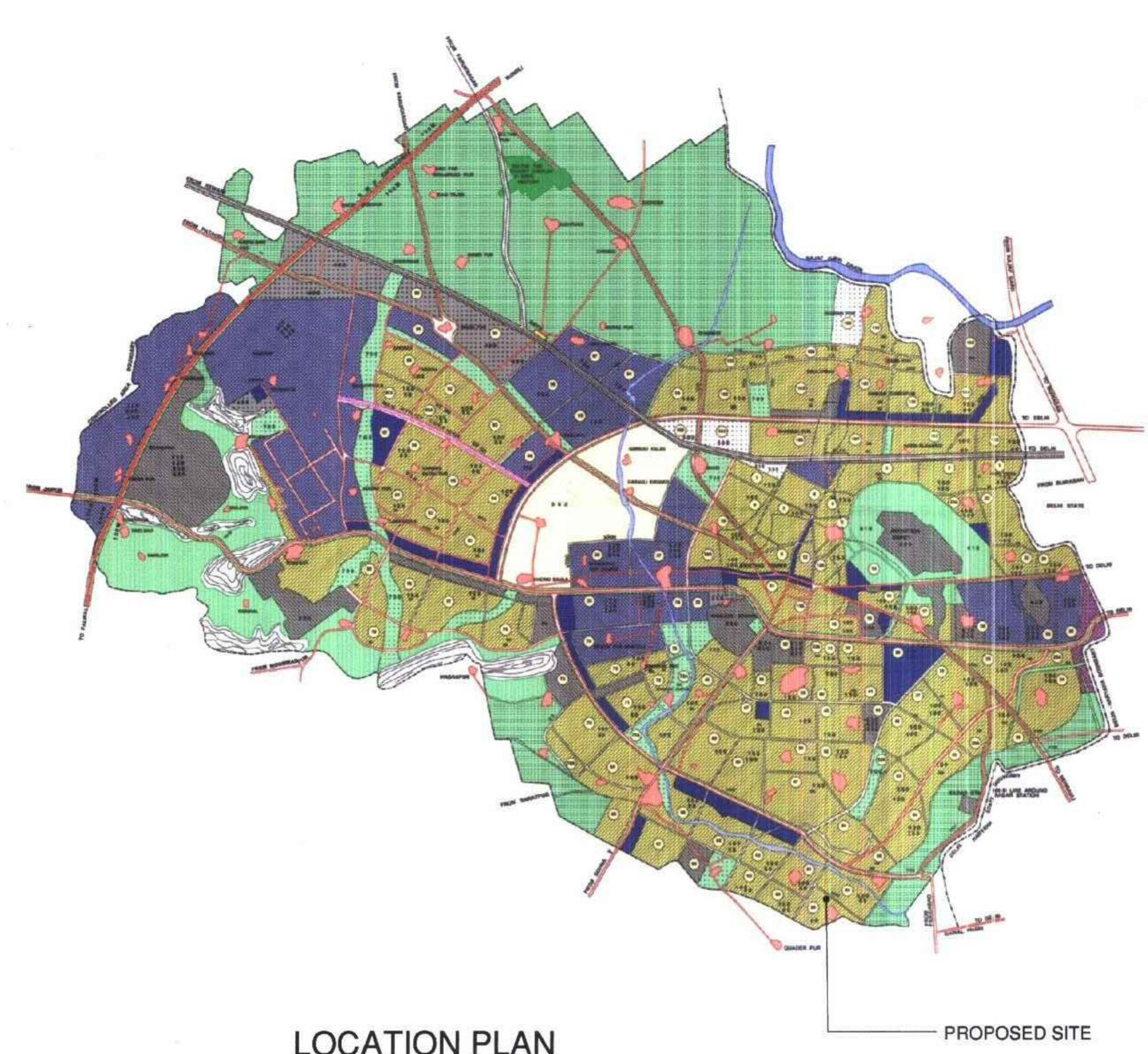

LOCATION PLAN

PROJECTS NAME:
GROUP HOUSING COLONY MEASURING
17.55 ACRES IN SEC-59, FALLING IN
THE REVENUE ESTATE OF VILLAGE
BEHRAMPUR, GURGAON.

- OWNERS:- M/S BASE EXPORTS PVT. LTD.
1. M/S ASPIRANT BUILDERS PVT. LTD.
305,KANCHAN HOUSE, KARAMPURA
COMMERCIAL, NEW DELHI .
 2. M/S BTVS BUILDWELL PVT. LTD.
C-4, FIRST FLOOR, MALVIYA NAGAR,
NEW DELHI.
 3. M/S BASE EXPORTS PVT. LTD.
5-1, SECOND FLOOR, BACK PORTION
SHAHPUR JAT, NEW DELHI.

ARCHITECTS SIGNATURE.

Ashok Choudhury
Ashok Choudhury
CA/2001/27298

OWNER'S SEAL & SIGNATURE.

Base Exports Private Limited
[Signature]
Authorized Signatory/ Director